

Features SBL900

Safe Work Load Stage 1:	2244 kN	(505 kips)
Safe Work Load Stage 2:	1481 kN	(333 kips)
Self Weight (incl. oil):	13350 kg	(29432 lbs)

Transport Dimensions

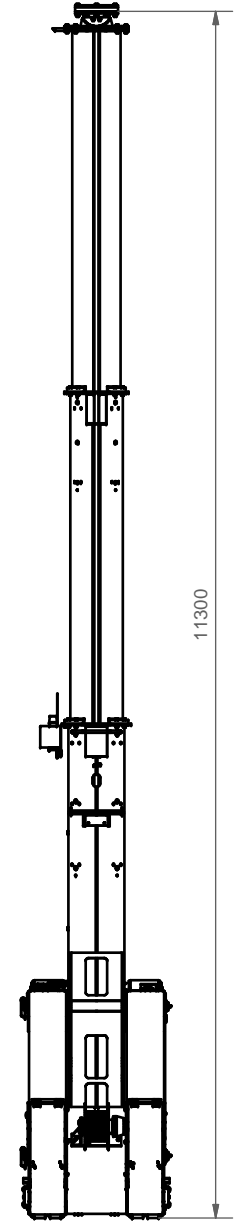
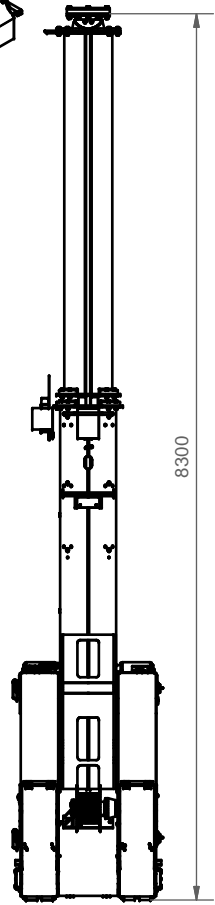
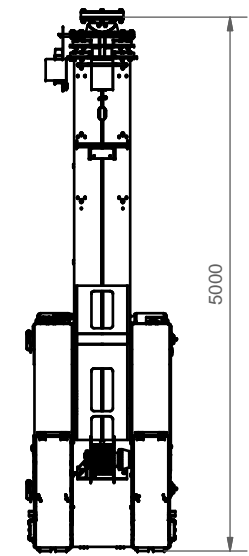
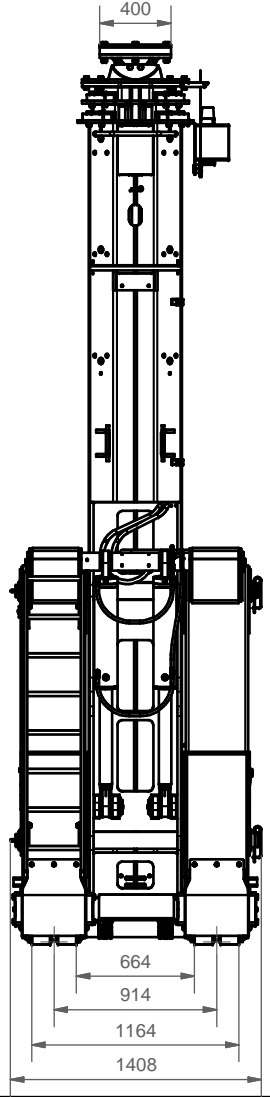
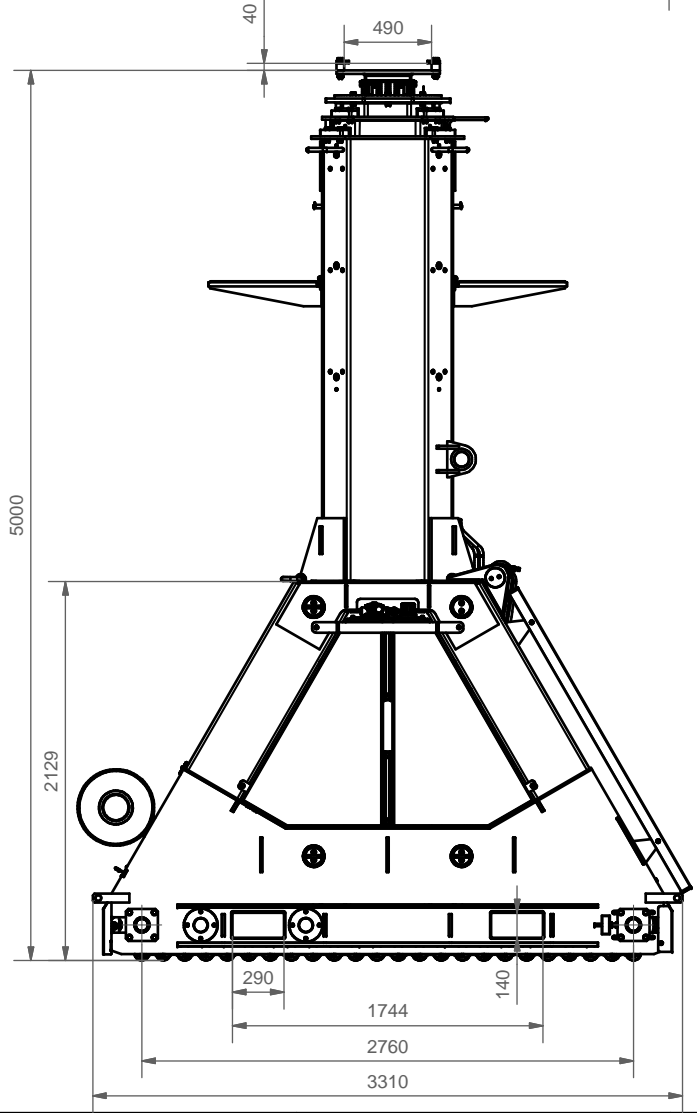
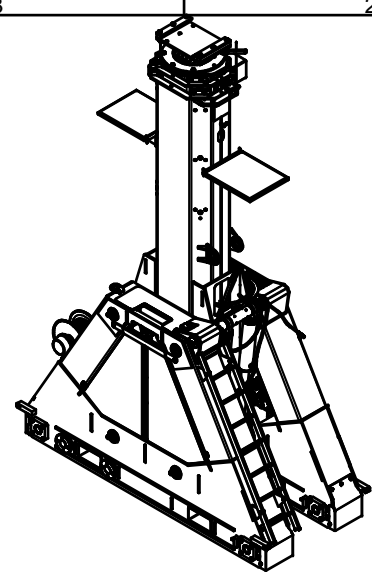
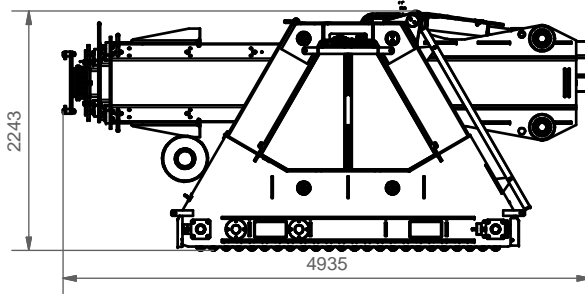

OPAALSTRAAT 44, 7554 TS HENGLO HOLLAND
 PO BOX 421, 7550 AK HENGLO HOLLAND
 TELEPHONE 074-2422045 FACSIMILE 074-2430338
ENERPAC
 COPYRIGHTS RESERVED

3rd ANGLE
 PROJECTION

Model Number: **SBL900**
 Drawing Number: **03454.50.00.00**

Main Assembly Number: **03454.01.00.00**
 REV: **0** DATE: **22-04-2014** SCALE: **1:30** FORM: **A3**